



High-frequency switch IGBT Module 1200V / 150A

Features

- ◆ Fast Switching Trench / Field Stop IGBT Technology
- ◆ Low Switching Losses
- ◆ Super Fast Diodes
- ◆ High Short Circuit Capability

Preliminary

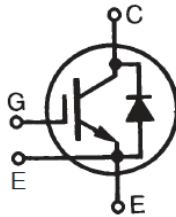

SOT-227

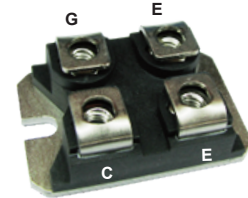

G = Gate, C = Collector, E = Emitter

Dimensions in inches and (millimeters)

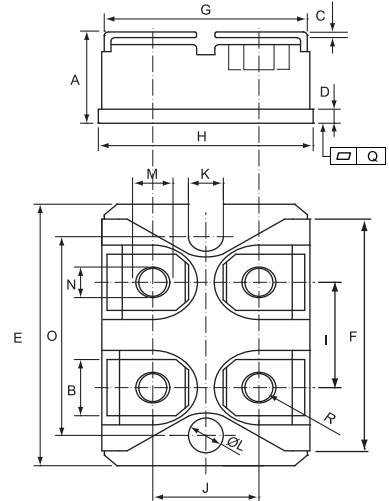

Applications

- ◆ Welder / Power Supply
- ◆ UPS / Inverter
- ◆ Industrial Motor Drive

Maximum Ratings (T_c = 25°C)

Item	Symbol	Rated Value	Unit
Collector-Emitter Voltage	V _{CEs}	1200	V
Gate-Emitter Voltage	V _{GES}	±20	V
DC-Collector Current	T _c = 80°C I _{C,nom.}	150	A
Repetitive Peak Collector Current	t _p = 1ms I _{CRM}	300	A
Total Power Dissipation	P _{tot}	890	W
Isolation Voltage (A.C. 1 minute) between All Terminals and Baseplate	V _{iso}	2500	V
DC Forward Current	I _F	150	A
Repetitive Peak Forward Current	t _p = 1ms I _{FRM}	300	A
Junction Temperature Range	T _J	-40~+150	°C
Storage Temperature Range	T _{stg}	-40~+125	°C
Mounting Torque (M4 screw)	To heatsink To terminals M _d	1.3 1.1	N.m
Weight		31.5	g

	DIMENSIONS			
	INCHES		MM	
	MIN	MAX	MIN	MAX
A	0.460	0.483	11.68	12.28
B	0.307	0.323	7.80	8.20
C	0.030	0.033	0.75	0.85
D	0.071	0.081	1.80	2.05
E	1.488	1.504	37.80	38.20
F	1.248	1.260	31.70	32.00
G	0.917	0.957	23.30	24.30
H	0.996	1.008	25.30	25.60
I	0.579	0.602	14.70	15.30
J	0.492	0.516	12.50	13.10
K	0.161	0.169	4.10	4.30
L	0.161	0.169	4.10	4.30
M	0.181	0.197	4.60	5.00
N	0.165	0.181	4.20	4.60
O	1.181	1.197	30.00	30.40
Q	-0.002	0.004	-0.05	0.10
R	M4*8			



■ **Electrical Characteristics** ($T_C=25^\circ\text{C}$)

Characteristic		Symbol	Test Conditions	Min.	Typ.	Max.	Unit
Collector-Emitter Cut-Off Current		I_{CES}	$V_{CE}=1200\text{V}$ $V_{GE}=0\text{V}$	-	-	1000	μA
Gate-Emitter Leakage Current		I_{GES}	$V_{GE}=20\text{V}$ $V_{CE}=0\text{V}$	-	-	100	nA
Collector-Emitter Saturation Voltage		$V_{CE(sat)}$	$I_C=150\text{A}, V_{GE}=15\text{V}$	-	1.90	2.15	V
Gate-Emitter Threshold Voltage		$V_{GE(th)}$	$V_{CE}=V_{GE}, I_C=4\text{mA}$	4.5	5.5	6.5	V
Input Capacitance		C_{ies}	$V_{CE}=25\text{V}, V_{GE}=0\text{V}, f=1\text{MHz}$	-	19.4	-	nF
Output Capacitance		C_{oes}	$V_{CE}=25\text{V}, V_{GE}=0\text{V}, f=1\text{MHz}$	-	0.48	-	nF
Reverse Transfer Capacitance		C_{res}	$V_{CE}=25\text{V}, V_{GE}=0\text{V}, f=1\text{MHz}$	-	0.28	-	nF
Switching Time	Rise Time	t_r	$V_{CC}=600\text{V}$ $I_C=150\text{A}$ $R_G=1\Omega$ $V_{GE}=\pm 15\text{V}$	-	0.06	-	μs
	Turn-On Time	$t_{d,on}$		-	0.2	-	
	Fall Time	t_f		-	0.075	-	
	Turn-Off Time	$t_{d,off}$		-	0.309	-	
Turn-on Energy Loss Per Pulse		E_{on}	$I_C=150\text{A}, V_{CC}=600\text{V}$ $V_{GE}=15\text{V}, R_G=1\Omega$	-	3.07	-	mJ
Turn-off Energy Loss Per Pulse		E_{off}	Inductive load	-	10.35	-	mJ
External Gate Resistance		R_G	Per Switch	1	-	15	Ω

■ **Free Wheeling Diode Ratings & Characteristics** ($T_C=25^\circ\text{C}$)

Characteristic		Symbol	Test Conditions	Min.	Typ.	Max.	Unit
Peak Forward Voltage		V_F	$I_F=150\text{A}, V_{GE}=0\text{V}$	-	1.8	2.3	V
Peak Reverse Recovery Current		I_{RM}	$I_F=150\text{A}, R_G=1\Omega$ $V_R=600\text{V}, V_{GE}=-15\text{V}$	-	31	-	A
Recovered Charge		Q_r	$I_F=150\text{A}, R_G=1\Omega$ $V_R=600\text{V}, V_{GE}=-15\text{V}$	-	8	-	μC
Reverse Recovery Energy		E_{rec}	$I_F=150\text{A}, R_G=1\Omega$ $V_R=600\text{V}, V_{GE}=-15\text{V}$	-	2.3	-	mJ
Reverse Recovery Time		T_{rr}	$I_F=150\text{A}, R_G=1\Omega$ $V_R=600\text{V}, V_{GE}=-15\text{V}$	-	252	-	ns

■ **Thermal Characteristics** ($T_C=25^\circ\text{C}$)

Characteristic		Symbol	Test Conditions	Min.	Typ.	Max.	Unit
Thermal Impedance	IGBT	$R_{th(j-c)}$	Junction to Case	-	-	0.14	$^\circ\text{C/W}$
	Diode			-	-	0.35	



Typical Characteristics

Preliminary Data

Fig.1 Output characteristic (Typical)

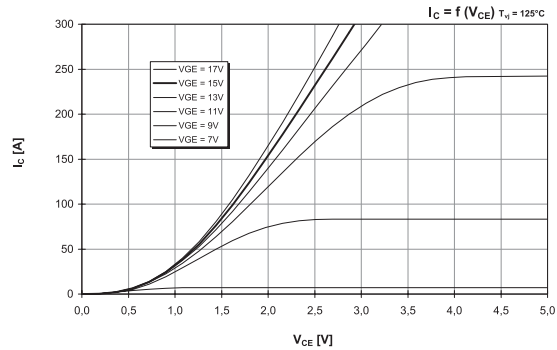
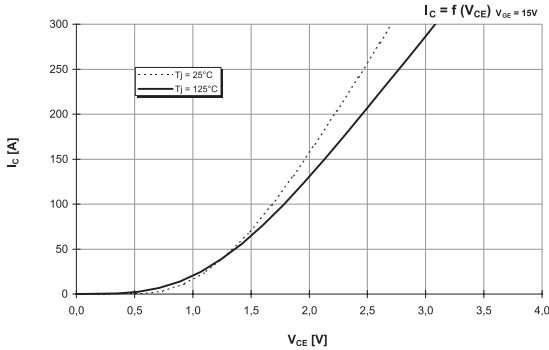

Fig.2 Transfer characteristic (Typical)

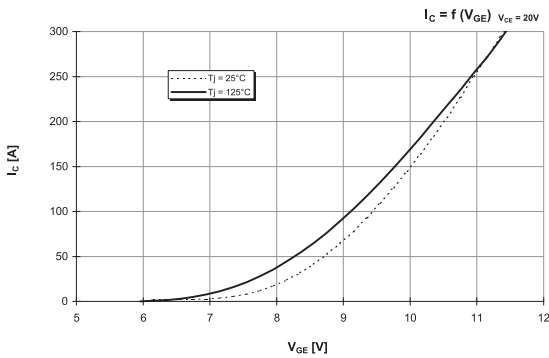

Fig.3 Forward characteristic of inverse diode (typical)

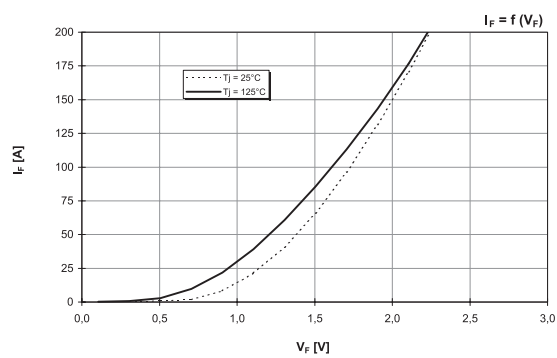

Fig.4 Switching losses (Typical)

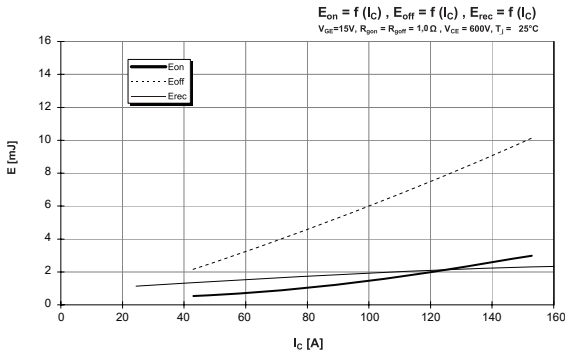

Fig.5 Switching losses IGBT, Inverter (typical)

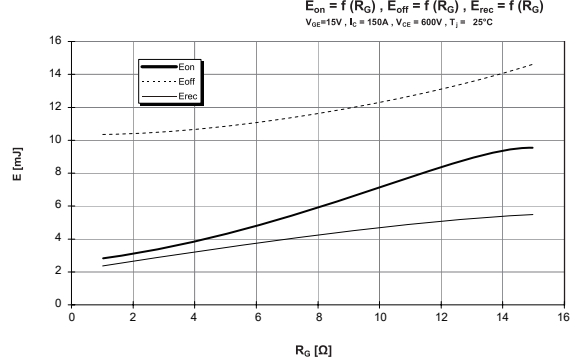
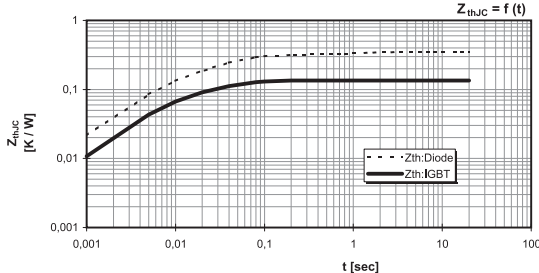
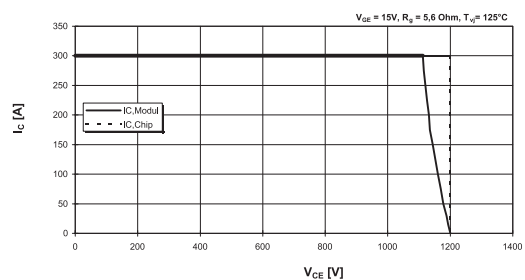

Fig.5 Transient thermal impedance



i	1	2	3	4
r_i [K/kW] : IGBT	44.54	33.9	21.52	0.04
τ_i [sec] : IGBT	0.006	0.029	0.043	1.014
r_i [K/kW] : Diode	68.24	101.68	52.66	27.42
τ_i [sec] : Diode	0.006	0.035	0.033	0.997

Fig.6 Reverse bias safe operation area (RBSOA)





Disclaimer

DACO Semiconductor reserve the right to make modifications, enhancements, improvements, corrections or other changes without further notice to this document and any product described herein.

DACO Semiconductor makes no warranty, representation or guarantee regarding the suitability of its products for any particular purpose, nor does DACO Semiconductor assume any liability arising out of the application or use of any product or circuit, and specifically disclaims any and all liability, including without limitation special, consequential or incidental damages.

Purchasers is responsible for its products and applications using DACO Semiconductor products, including compliance with all laws, regulations and safety requirements or standards, regardless of any support or applications information provided by DACO Semiconductor. "Typical" parameters which may be provided in DACO Semiconductor data sheets and/or specifications can and do vary in different applications and actual performance may vary over time. All operating parameters, including "Typicals" must be validated for each customer application by customer's technical experts.

DACO Semiconductor products are not designed, authorized or warranted to be suitable for use in life support, life-critical or safety-critical systems or equipment, nor in applications where failure or malfunction of DACO Semiconductor's product can reasonably be expected to result in personal injury, death or severe property or environmental damage. DACO Semiconductor accept no liability for inclusion and/or use of DACO Semiconductor's products in such equipment or applications and therefore such inclusion and/or use is at the customer's own risk.

Purchasers buy or use DACO Semiconductor products for any such unintended or unauthorized application, Purchasers shall indemnify and hold DACO Semiconductor and its suppliers and distributors harmless against all claims, costs, damages, and expenses, and reasonable attorney fees arising out of, directly or indirectly, any claim of personal injury or death associated with such unintended or unauthorized use, even if such claim alleges that DACO Semiconductor was negligent regarding the design or manufacture of the part.

No part of this publication may be reproduced or transmitted in any form or by any means, electronic or mechanical, including photocopying and recording, or any information storage or retrieval system, or otherwise, without the prior written permission of DACO Semiconductor Co., Ltd.